

CARTER ARCHITECTURAL PANELS, INC. FLORIDA BUILDING CODE TEST REPORT

SCOPE OF WORK

TAS 201, TAS 202, AND TAS 203 TESTING ON ETALBOND® FR (4 MM) CLADDING PANELS
FIXED ON FUSION™ DRILLFREE™ ATTACHMENT SYSTEM

REPORT NUMBER

L6030.01-109-18

TEST DATE(S)

08/25/2022 – 08/31/2022

ISSUE DATE

10/19/22

RECORD RETENTION END DATE

08/31/2032

PAGES

29

DOCUMENT CONTROL NUMBER

RT-R-AMER-Test-2816 (07/12/22)

© 2017 INTERTEK

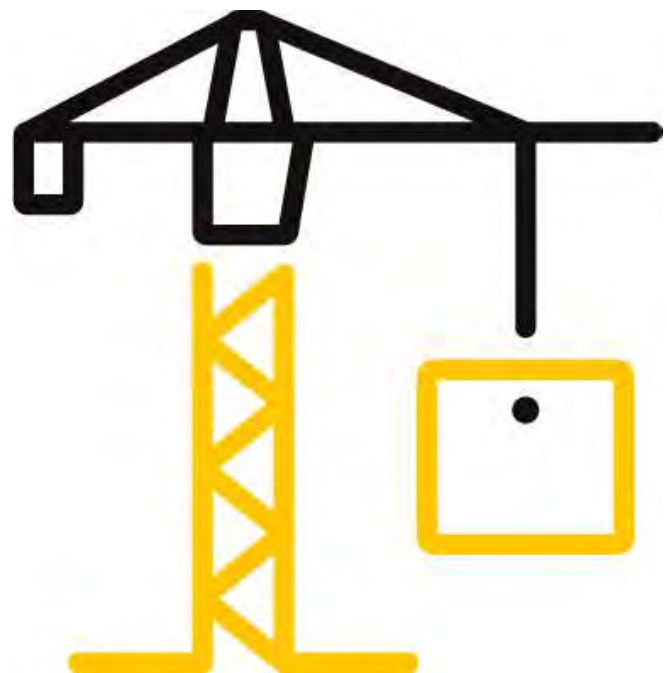

TEST REPORT FOR CARTER ARCHITECTURAL PANELS, INC.

Report No.: L6030.01-109-18

Date: 10/19/22

REPORT ISSUED TO

CARTER ARCHITECTURAL PANELS, INC.

7925 East Ray Road, Suite 133

Mesa, Arizona 85212

SECTION 1

SCOPE

Architectural Testing, Inc. (an Intertek company) dba Intertek Building & Construction (B&C) was contracted by Carter Architectural Panels, Inc. to perform TAS 201, TAS 202, and TAS 203 testing in accordance with Florida Building Code for High Velocity Hurricane Zone requirements on their Fusion™ DrillFree™ System clad with etalbond® FR (4 mm), metal composite material panels. Results obtained are tested values and were secured by using the designated test method(s). Testing was conducted at the Intertek B&C test facility in York, Pennsylvania.

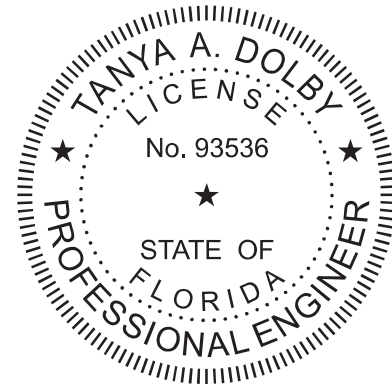

For INTERTEK B&C:

COMPLETED BY:	Jason R. Zeller
TITLE:	Technician – Product Testing
SIGNATURE:	 <small>Digitally Signed by: Jason Zeller</small>
DATE:	10/19/22

REVIEWED BY:	Tanya A. Dolby, P.E.
TITLE:	Engineering Manager – Engineering Services
SIGNATURE:	 <small>Digitally Signed by: Tanya Dolby</small>
DATE:	10/19/22

JRZ:nls

2022.10.20 08:29:42 -04'00'

This report is for the exclusive use of Intertek's Client and is provided pursuant to the agreement between Intertek and its Client. Intertek's responsibility and liability are limited to the terms and conditions of the agreement. Intertek assumes no liability to any party, other than to the Client in accordance with the agreement, for any loss, expense or damage occasioned by the use of this report. Only the Client is authorized to permit copying or distribution of this report and then only in its entirety. Any use of the Intertek name or one of its marks for the sale or advertisement of the tested material, product or service must first be approved in writing by Intertek. The observations and test results in this report are relevant only to the sample(s) tested. This report by itself does not imply that the material, product, or service is or has ever been under an Intertek certification program.

TEST REPORT FOR CARTER ARCHITECTURAL PANELS, INC.

Report No.: L6030.01-109-18

Date: 10/19/22

SECTION 2

SUMMARY OF TEST RESULTS

The specimens tested met the performance requirements set forth in the protocols.

TEST SPECIMEN	TEST PROTOCOL	DESIGN PRESSURE
1 & 2	TAS 202	+100.00 / -75.00 psf
3	TAS 201/203 (Large Missile)	+100.00 / -75.00 psf
4	TAS 201/203 (Large Missile)	+100.00 / -75.00 psf
5	TAS 201/203 (Large Missile)	+100.00 / -75.00 psf

SECTION 3

TEST METHOD(S)

The specimens were evaluated in accordance with the following:

TAS 201-94, *Impact Test Procedures*

TAS 202-94, *Criteria for Testing Impact & Non Impact Resistant Building Envelope Components Using Uniform Static Air Pressure*

TAS 203-94, *Criteria for Testing Products Subject to Cyclic Wind Pressure Loading*

SECTION 4

MATERIAL SOURCE/INSTALLATION

Test specimens were provided by the client. Representative samples of the test specimens will be retained by Intertek B&C for a minimum of ten years from the test completion date.

The specimen was installed onto a wood-wrapped steel stud wall. The rough opening allowed for no shim space. The interior perimeter of the wall was sealed with sealant. Installation of the tested product was performed by the client.

Test Wall Construction:

The test wall was constructed of 18-gauge, 2x6 steel studs, spaced 16" on center. The studs were secured with #8 x 1/2" self-tapping pancake head screws, through the head and sill, and into the studs. The test wall was sheathed with two 4' by 8', 5/8" thick sheets of exterior gypsum with a single horizontal joint and secured to studs with #8 x 1" pan head screws. The steel stud wall was then wrapped with nominal 2x10 lumber and secured with #10 x 1-1/2" pan head screws spaced 10" on center and staggered along perimeter, through the steel studs and into the lumber. The jambs of the wrap were secured to the head and sill of the wrap with #8 x 3" drywall screws, through the jambs and into the head and sill.

TEST REPORT FOR CARTER ARCHITECTURAL PANELS, INC.

Report No.: L6030.01-109-18

Date: 10/19/22

Specimen Installation:

1-1/2" wide by 1" high 18-gauge G-90 galvanized steel hat channels were installed horizontally spaced 16" on center and fastened through the hat channel, through the sheathing, and into the steel studs using two #14 x 1-1/2" self-drilling hex head screws with steel and rubber washers every 16" on center. A 1-1/2" wide by 1/2" high 0.100" thick extruded aluminum retaining strip was installed horizontally at the bottom hat channel, fastened with #14 x 1" self-drilling hex head screws, through the retaining strip and into the hat channel, spaced 16" on center. A 94-1/2" by 47" etalbond® FR (4 mm) panel was installed at the lower half of the test wall. The bottom of the etalbond® FR panel was interlocked with the retaining strip and fastened with two extruded aluminum clips on each side and four clips along the top of the panel. The clips were slid into the mating track on a custom extruded aluminum installation rail along the perimeter of the etalbond® FR panel and fastened to the rail using a #10 x 1/2" self-drilling socket head screw per clip. The clips were fastened through the clip and into the hat channels using #14 x 1" self-drilling hex head screws with steel and rubber washers. Two 47" by 47" etalbond® FR panels were installed on the upper half of the test wall. The bottoms of the two etalbond® FR panels were interlocked into the clips along the top of the lower panel. Two side clips and two top clips were slid into the mating track of the installation rail along the perimeter of each 47" by 47" panel. The clips were fastened through the clip and into the hat channels using #14 x 1" self-drilling hex head screws with steel and rubber washers. A 94-1/2" by 2" etalbond® FR reveal strip consisting of three layers, an interior and exterior 0.020" thick aluminum skin and a 0.120" thick core, was slid horizontally between the panels. Another 47" by 2" reveal strip was slid vertically between the two top panels.

TAS 202 Panel Description:

The etalbond® FR panels measured 0.165" (4 mm) thick and were comprised of two pre-coated 0.500 mm thick aluminum skins with a fire-retardant core. The rear side of the panel was routed at a depth of 0.121" to 0.13" (~3.08 - 3.30 mm) and turned inwards one time with a height of 1" around the etalbond® FR panel perimeter. Each corner was mitered and interlocked. Custom extruded Fusion™ perimeter rails were placed inside the single return track around the perimeter of the interior side of the panel. The meeting points of the rails at each corner were reinforced with 2-1/2" by 2-1/2" by .080" vertical aluminum corner bracket, fastened with two #8 x 3/4" self-drilling Toraxlig screws. Each rail was also secured with Carter's proprietary 3/16" by 7/8" "double-bulb" rivets, spaced 16" on center. Carter's patented 2" wide by 1-1/2" tall integrated extruded aluminum stiffeners were installed, 16" on center, on the interior of the panel, secured at the ends with one 2-1/2" by 2-1/2" by .080" vertical aluminum angle at each end, fastened with two #8 x 3/4" self-drilling Toraxlig screws. The stiffeners were primarily secured by Carter's proprietary "Structural Stiffener Tape" and a secondary bead of structural silicone on each beveled edge of the stiffener.

TEST REPORT FOR CARTER ARCHITECTURAL PANELS, INC.

Report No.: L6030.01-109-18

Date: 10/19/22

TAS 201/203 Panel Description:

The etalbond® FR panels measured 0.165" (4 mm) thick and were comprised of two pre-coated 0.500 mm thick aluminum skins with a fire-retardant core. The rear side of the panel was routed at a depth of 0.121" to 0.13" (~3.08 - 3.30 mm) and turned inwards one time with a height of 1" around the etalbond® FR panel perimeter and mitered at each corner. A 0.038" thick sheet of G-90 galvanized steel was adhered to the interior of the panel using Carter's proprietary "Structural Stiffener Tape". Custom extruded Fusion™ perimeter rails were placed inside the single return track around the perimeter of the interior side of the panel, pinning the galvanized steel sheet between the panel and Fusion™ perimeter rails. The meeting points of the rails at each corner were reinforced with 2-1/2" by 2-1/2" by .080" vertical aluminum corner bracket, fastened with two #8 x 3/4" self-drilling Toraxlig screws. Each rail was also secured with Carter's proprietary 3/16" by 7/8" "double-bulb" rivets, spaced 16" on center. Carter's patented 2" wide by 1-1/2" tall integrated extruded aluminum stiffeners were installed, 16" on center, on the interior of the panel, secured to the galvanized steel sheet, at the ends with one 2-1/2" by 2-1/2" by .080" vertical aluminum angle at each end, fastened with two #8 x 3/4" self-drilling Toraxlig screws. The stiffeners were primarily secured by Carter's proprietary "Structural Stiffener Tape" and a secondary bead of structural silicone on each beveled edge of the stiffener.

SECTION 5 EQUIPMENT

Cannon: Constructed from steel piping utilizing compressed air to propel the missile - A1207

Missile: 2x4 Southern Pine

Timing Device: Electronic beam type

Cycling Mechanism: Computer controlled centrifugal blower with electronic pressure measuring device - 003921, 005406

Deflection Measuring Device: Linear Transducers - 003420, 003439, 62189, 64325, 64368, 64460, 64461, Y003056, Y003060

Tape Measure Verification: 63788

Weather Station: 63316

SECTION 6 LIST OF OFFICIAL OBSERVERS

NAME	COMPANY
Joel McKinley	Carter Architectural Panels, Inc.
Bruce R. Bourne	Carter Architectural Panels, Inc.
Mark A. Landry	Carter Architectural Panels, Inc.
Ken R. Stough	Intertek B&C
Jason R. Zeller	Intertek B&C

TEST REPORT FOR CARTER ARCHITECTURAL PANELS, INC.

Report No.: L6030.01-109-18

Date: 10/19/22

SECTION 7

TEST SPECIMEN DESCRIPTION

Product Type: Metal Composite Material Panels

Series/Model: Fusion™ DrillFree™ System Cladded with etalbond® FR (4 mm)

Product Size(s):

OVERALL AREA:	WIDTH		HEIGHT	
	millimeters	inches	millimeters	inches
5.9 m ² (64.0 ft ²)				
Overall size	2438	96	2438	96
Lower etalbond® FR panel, 5.2	2400	94-1/2	1194	47
Upper etalbond® FR panel (2), 5.2	1194	47	1194	47

Weatherstripping: No weatherstripping was utilized.

Drainage:

DRAINAGE METHOD	SIZE	QUANTITY	LOCATION
Weepslots	11/16" long by 3/16" wide	4 per panel	Bottom of upper panel, 6" from ends and 11-1/2" on center
Weepholes with open cell foam	7/16" diameter	4 per panel	Bottom installation rail of upper panel, 6" from ends and 11-1/2" on center with open cell foam directly behind weepholes
Weepslots	11/16" long by 3/16" wide	7	Bottom of lower panel, 6" from ends and 13-3/4" on center
Weepholes with open cell foam	7/16" diameter	7	Bottom installation rail of lower panel, 6" from ends and 13-3/4" on center with open cell foam directly behind weepholes

TEST REPORT FOR CARTER ARCHITECTURAL PANELS, INC.

Report No.: L6030.01-109-18

Date: 10/19/22

**SECTION 8
TEST RESULTS**

Test Specimen #1: Preload per TAS 202:

INDICATOR LOCATION	Deflection at +75.00 psf	NET DEFLECTION (in.)		Permanent Set at +75.00 psf	PERMANENT SET (in.)	
		MEASURED	ALLOWED		MEASURED	ALLOWED
1	0.16	0.95	1.58	0.06	0.05	N/A
2	1.05			0.08		
3	0.05			0.01		
4	0.12	0.53	0.78	0.02	<0.01	
5	0.73			0.02		
6	0.28			0.02		

Test Specimen #2: Preload per TAS 202:

INDICATOR LOCATION	Deflection at -56.25 psf	NET DEFLECTION (in.)		Permanent Set at -56.25 psf	PERMANENT SET (in.)	
		MEASURED	ALLOWED		MEASURED	ALLOWED
1	0.15	0.81	1.58	0.02	0.07	N/A
2	0.92			0.08		
3	0.07			0.01		
4	0.18	0.43	0.78	0.03	0.02	
5	0.68			0.08		
6	0.32			0.09		

Test Specimen #1: Design Load per TAS 202

INDICATOR LOCATION	Deflection at +100.00 psf	NET DEFLECTION (in.)		Permanent Set at +100.00 psf	PERMANENT SET (in.)	
		MEASURED	ALLOWED		MEASURED	ALLOWED
1	0.18	1.24	1.58	0.07	0.07	N/A
2	1.36			0.11		
3	0.06			0.01		
4	0.15	0.67	0.78	0.02	0.01	
5	0.92			0.03		
6	0.35			0.02		

Test Specimen #2: Design per TAS 202:

INDICATOR LOCATION	Deflection at -75.00 psf	NET DEFLECTION (in.)		Permanent Set at -75.00 psf	PERMANENT SET (in.)	
		MEASURED	ALLOWED		MEASURED	ALLOWED
1	0.23	1.07	1.58	0.03	0.10	N/A
2	1.23			0.12		
3	0.10			0.01		
4	0.27	0.53	0.78	0.04	0.02	
5	0.89			0.09		
6	0.45			0.11		

TEST REPORT FOR CARTER ARCHITECTURAL PANELS, INC.

Report No.: L6030.01-109-18

Date: 10/19/22

Test Specimen #1: Overload per TAS 202

INDICATOR LOCATION	Deflection at +150.00 psf	NET DEFLECTION (in.)		Permanent Set at +150.00 psf	PERMANENT SET (in.)	
		MEASURED	ALLOWED		MEASURED	ALLOWED
1	0.22	1.47	1.58	0.07	0.11	N/A
2	1.62			0.15		
3	0.08			0.01		
4	0.32	0.68	0.78	0.03	0.03	
5	1.15			0.06		
6	0.63			0.04		

Test Specimen #2: Overload per TAS 202

INDICATOR LOCATION	Deflection at -112.50 psf	NET DEFLECTION (in.)		Permanent Set at -112.50 psf	PERMANENT SET (in.)	
		MEASURED	ALLOWED		MEASURED	ALLOWED
1	0.42	1.55	1.58	0.06	0.15	N/A
2	1.91			0.19		
3	0.30			0.02		
4	0.46	0.71	0.78	0.09	0.02	
5	1.34			0.16		
6	0.80			0.19		

Note 1: Positive and negative uniform static load test loads were held for 30 seconds.

Note 2: Tape and film were used to seal against air leakage during structural testing. In our opinion, the tape and film did not influence the results of the test.

Note 3: See Sketch #1 for indicator locations. Deflection/permanent set reported is the overall deflection between three points (longest unsupported span) which accounts for support movement.

TEST REPORT FOR CARTER ARCHITECTURAL PANELS, INC.

Report No.: L6030.01-109-18

Date: 10/19/22

Protocol TAS 201-94, Large Missile Impact Procedures

Test Dates: 08/24/22 through 08/29/22

The temperature range during testing was 27° - 30°C (81° - 86°F). The results are tabulated as follows:

Test Specimen #3:

IMPACT #	MISSILE WEIGHT (lbs.)	MISSILE LENGTH (in.)	MISSILE VELOCITY (ft./sec.)	DEFLECTION	
				INSTANTANEOUS (in.)	PERMANENT (in.)
1	9.22	98-1/4	51.0	N/A	N/A
2	9.22	98-1/4	49.7	N/A	N/A
3	9.22	98-1/4	49.1	N/A	N/A
4	9.22	98-1/4	49.6	N/A	N/A
5	9.22	98-1/4	49.7	N/A	N/A

Note 4: See Sketch #2 for impact locations.

Test Specimen #4:

IMPACT #	MISSILE WEIGHT (lbs.)	MISSILE LENGTH (in.)	MISSILE VELOCITY (ft./sec.)	DEFLECTION	
				INSTANTANEOUS (in.)	PERMANENT (in.)
1	9.22	98-1/4	49.5	N/A	N/A
2	9.22	98-1/4	49.9	N/A	N/A
3	9.22	98-1/4	49.9	N/A	N/A
4	9.22	98-1/4	49.9	N/A	N/A
5	9.22	98-1/4	49.8	N/A	N/A

Note 5: See Sketch #3 for impact locations.

Test Specimen #5:

IMPACT #	MISSILE WEIGHT (lbs.)	MISSILE LENGTH (in.)	MISSILE VELOCITY (ft./sec.)	DEFLECTION	
				INSTANTANEOUS (in.)	PERMANENT (in.)
1	9.22	98-1/4	49.8	N/A	N/A
2	9.22	98-1/4	49.8	N/A	N/A
3	9.22	98-1/4	50.0	N/A	N/A
4	9.22	98-1/4	50.0	N/A	N/A
5	9.22	98-1/4	50.5	N/A	N/A

Note 6: See Sketch #4 for impact locations.

TEST REPORT FOR CARTER ARCHITECTURAL PANELS, INC.

Report No.: L6030.01-109-18

Date: 10/19/22

Protocol TAS 203-94, Cyclic Wind Pressure Loading

Test Date(s): 08/26/22 through 08/31/22

The temperature range during testing was 27° - 30°C (81° - 86°F). The results are tabulated as follows:

Test Specimen #3: Cyclic Test Spectrum and Average Cycle Time per TAS 203:

DESIGN PRESSURE	STAGE		
+100.00 psf	1	2	3
POSITIVE PRESSURE RANGE (psf)	0 – 50.0	0 – 60	0 – 130
AVERAGE CYCLE TIME (sec.)	2.93	2.90	N/A
NUMBER OF CYCLES	600	70	1
-75.00 psf	4	5	6
NEGATIVE PRESSURE RANGE (psf)	0 – 37.5	0 – 45.0	0 – 97.5
AVERAGE CYCLE TIME (sec.)	2.85	2.91	N/A
NUMBER OF CYCLES	600	70	1

Positive Cyclic Load per TAS 203:

INDICATOR LOCATION	MAXIMUM DEFLECTION (in.)	PERMANENT SET (in.)	PERCENT RECOVERY	
			MEASURED %	ALLOWED %
1-3	1.355	0.125	91	> 90
4-5	1.090	0.09	92	> 90

Negative Cyclic Load per TAS 203:

INDICATOR LOCATION	MAXIMUM DEFLECTION (in.)	PERMANENT SET (in.)	PERCENT RECOVERY	
			MEASURED %	ALLOWED %
1-3	1.515	0.130	91	> 90
4-6	0.540	0.010	98	> 90

Note 7: See Sketch #1 for indicator locations. Deflection/permanent set reported is the overall deflection between three points (longest unsupported span) which accounts for support movement.

TEST REPORT FOR CARTER ARCHITECTURAL PANELS, INC.

Report No.: L6030.01-109-18

Date: 10/19/22

Test Specimen #4: Cyclic Test Spectrum and Average Cycle Time per TAS 203:

DESIGN PRESSURE	STAGE		
+100.00 psf	1	2	3
POSITIVE PRESSURE RANGE (psf)	0 – 50.0	0 – 60.0	0 – 130.0
AVERAGE CYCLE TIME (sec.)	2.81	2.96	N/A
NUMBER OF CYCLES	600	70	1
-75.00 psf	4	5	6
NEGATIVE PRESSURE RANGE (psf)	0 – 37.5	0 – 45.0	0 – 97.5
AVERAGE CYCLE TIME (sec.)	3.00	2.98	N/A
NUMBER OF CYCLES	600	70	1

Positive Cyclic Load per TAS 203:

INDICATOR LOCATION	MAXIMUM DEFLECTION (in.)	PERMANENT SET (in.)	PERCENT RECOVERY	
			MEASURED %	ALLOWED %
1-3	1.165	0.045	96	> 90
4-6	0.785	0.010	99	> 90

Negative Cyclic Load per TAS 203:

INDICATOR LOCATION	MAXIMUM DEFLECTION (in.)	PERMANENT SET (in.)	PERCENT RECOVERY	
			MEASURED %	ALLOWED %
1-3	1.385	0.090	94	> 90
4-6	0.615	0.025	96	> 90

Note 8: See Sketch #1 for indicator locations. Deflection/permanent set reported is the overall deflection between three points (longest unsupported span) which accounts for support movement.

TEST REPORT FOR CARTER ARCHITECTURAL PANELS, INC.

Report No.: L6030.01-109-18

Date: 10/19/22

Test Specimen #5: Cyclic Test Spectrum and Average Cycle Time per TAS 203:

DESIGN PRESSURE	STAGE		
+100.00 psf	1	2	3
POSITIVE PRESSURE RANGE (psf)	0 – 50.0	0 – 60.0	0 – 130.0
AVERAGE CYCLE TIME (sec.)	3.00	2.92	N/A
NUMBER OF CYCLES	600	70	1
-75.00 psf	4	5	6
NEGATIVE PRESSURE RANGE (psf)	0 – 37.5	0 – 45.0	0 – 97.5
AVERAGE CYCLE TIME (sec.)	2.93	2.89	N/A
NUMBER OF CYCLES	600	70	1

Positive Cyclic Load per TAS 203:

INDICATOR LOCATION	MAXIMUM DEFLECTION (in.)	PERMANENT SET (in.)	PERCENT RECOVERY	
			MEASURED %	ALLOWED %
1-3	1.025	0.065	94	> 90
4-6	0.715	0.065	91	> 90

Negative Cyclic Load per TAS 203:

INDICATOR LOCATION	MAXIMUM DEFLECTION (in.)	PERMANENT SET (in.)	PERCENT RECOVERY	
			MEASURED %	ALLOWED %
1-3	1.430	0.090	94	> 90
4-6	0.625	0.010	98	> 90

Note 9: See Sketch #1 for indicator locations. Deflection/permanent set reported is the overall deflection between three points (longest unsupported span) which accounts for support movement.

TEST REPORT FOR CARTER ARCHITECTURAL PANELS, INC.

Report No.: L6030.01-109-18

Date: 10/19/22

SECTION 9

CONCLUSIONS

The large missiles impacted each intended target. Each impact location was carefully inspected. No signs of penetration, rupture, or opening after the large missile impact test were observed; as such, each test specimen satisfies the large missile requirements of TAS 201. Upon completion of testing, specimens tested for TAS 201-94 met the requirements of Section 1626 of the Florida Building Code, Building.

No signs of failure were observed in any area of the test specimen during the TAS 202 testing; as such, the test specimen satisfies the requirements of TAS 202. Upon completion of testing, specimens tested for TAS 202-94 met the requirements of Section 1620 of the Florida Building Code, Building.

No signs of failure were observed in any area of the test specimens during the cyclic load test; as such, the test specimens satisfy the cyclic load requirements of TAS 203. Upon completion of testing, specimens tested for TAS 203-94 met the requirements of Section 1625 of the Florida Building Code, Building.

This report does not constitute certification of this product nor an opinion or endorsement by this laboratory. Intertek B&C will service this report for the entire test record retention period. The test record retention period ends ten years after the test date. Test records, such as detailed drawings, datasheets, representative samples of test specimens, or other pertinent project documentation, will be retained for the entire test record retention period.

Unless differently required, Intertek reports apply the "Simple Acceptance" rule, also called "Shared Risk approach," of ILAC-G8:09/2019, Guidelines on Decision Rules and Statements of Conformity.

TEST REPORT FOR CARTER ARCHITECTURAL PANELS, INC.

Report No.: L6030.01-109-18

Date: 10/19/22

SECTION 10 SKETCH(ES)

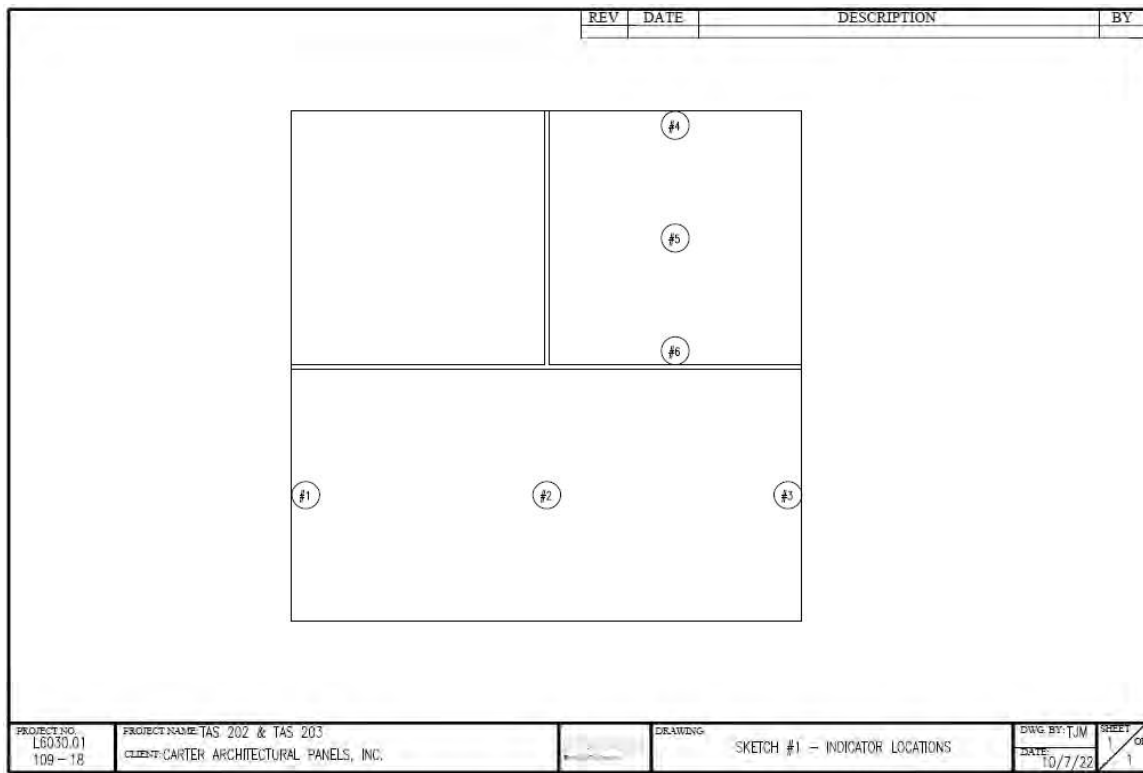

Sketch No. 1
TAS 202 and 203 Indicator Locations

TEST REPORT FOR CARTER ARCHITECTURAL PANELS, INC.

Report No.: L6030.01-109-18

Date: 10/19/22

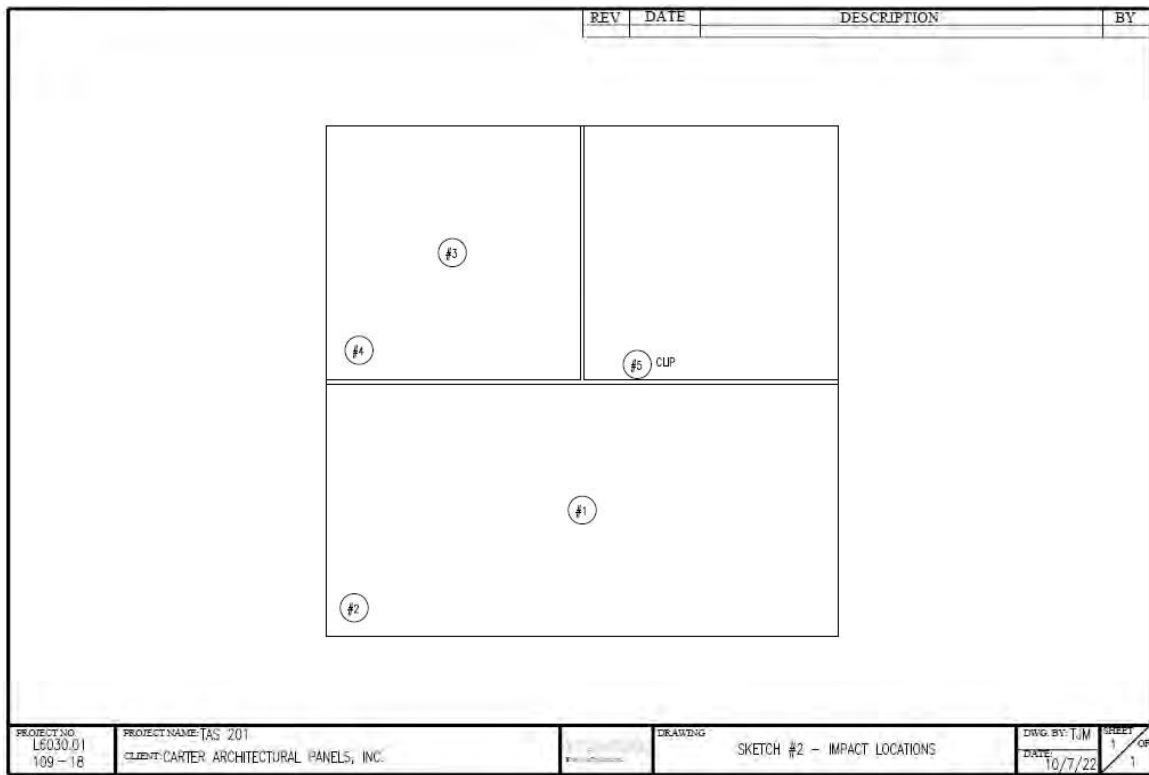

Sketch No. 2
TAS 201 Impact Locations

TEST REPORT FOR CARTER ARCHITECTURAL PANELS, INC.

Report No.: L6030.01-109-18

Date: 10/19/22

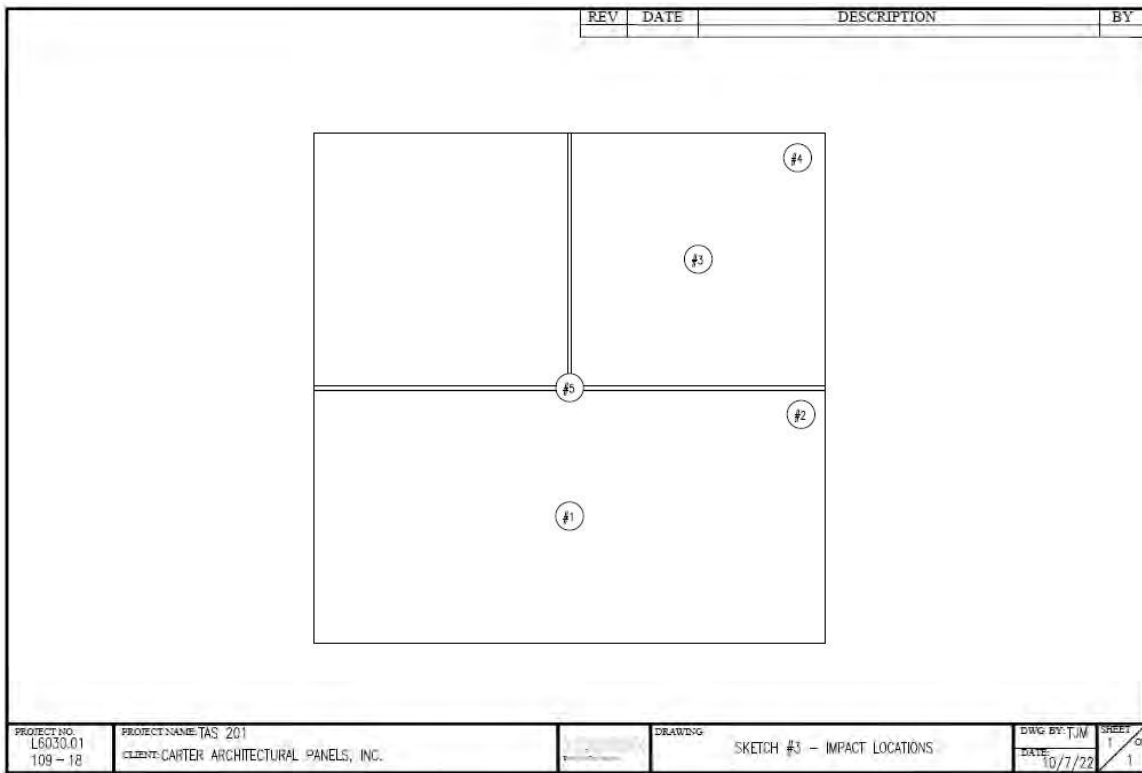

Sketch No. 3
TAS 201 Impact Locations

TEST REPORT FOR CARTER ARCHITECTURAL PANELS, INC.

Report No.: L6030.01-109-18

Date: 10/19/22

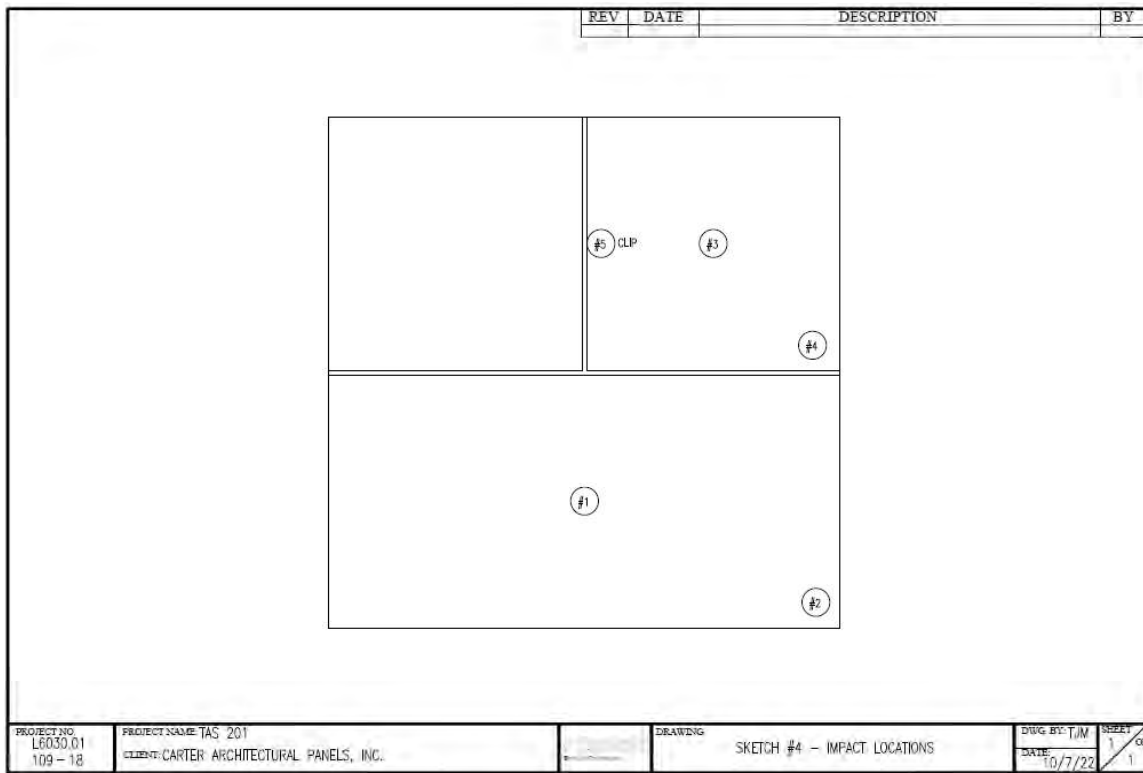

Sketch No. 4
TAS 201 Impact Locations

TEST REPORT FOR CARTER ARCHITECTURAL PANELS, INC.

Report No.: L6030.01-109-18

Date: 10/19/22

SECTION 11 PHOTOGRAPHS

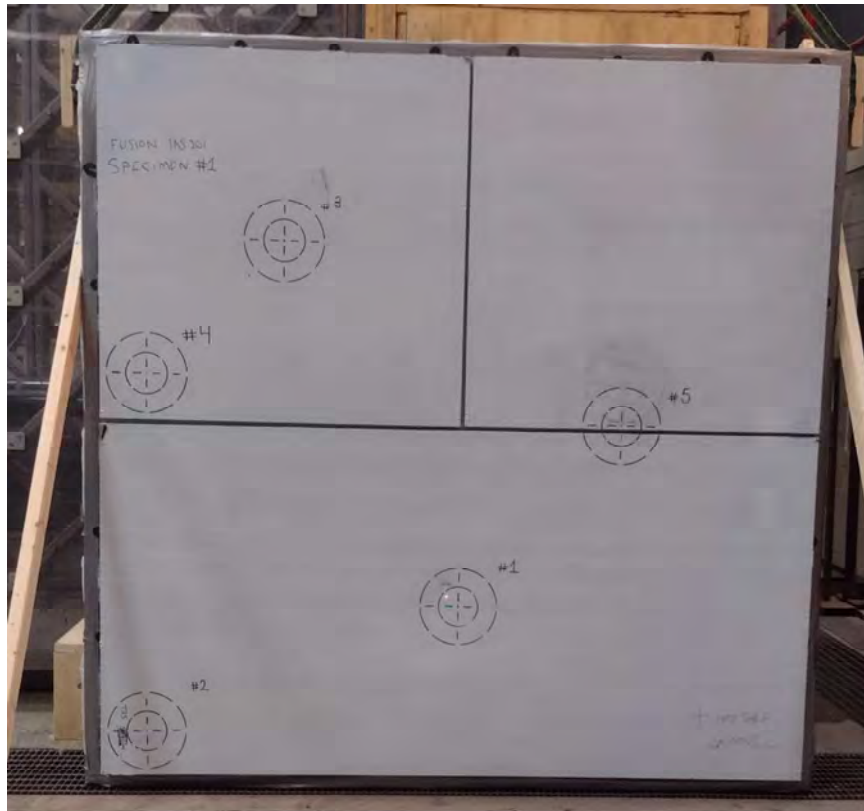

Photo No. 1
etalbond® FR (Cladding Panels) Fixed on Fusion™ Drillfree™ Attachment System
Specimen #3 Prior to Testing

TEST REPORT FOR CARTER ARCHITECTURAL PANELS, INC.

Report No.: L6030.01-109-18

Date: 10/19/22



Photo No. 2

**etalbond® FR (Cladding Panels) Fixed on Fusion™ Drillfree™ Attachment System
Specimen #4 Prior to Testing**

TEST REPORT FOR CARTER ARCHITECTURAL PANELS, INC.

Report No.: L6030.01-109-18

Date: 10/19/22

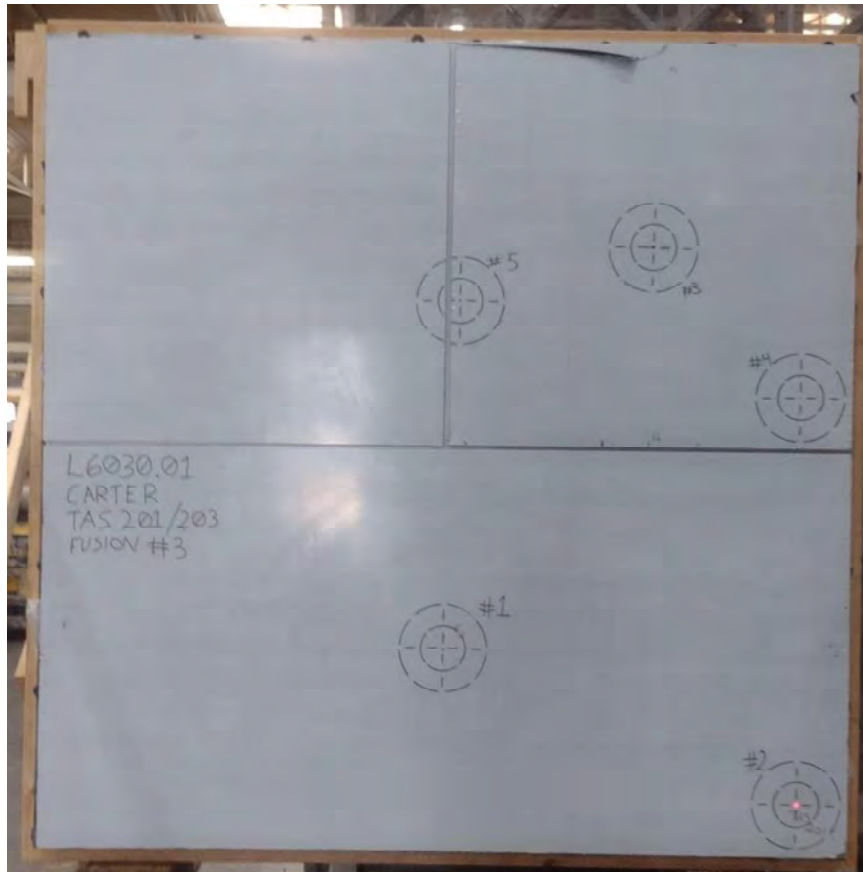

Photo No. 3
etalbond® FR (Cladding Panels) Fixed on Fusion™ Drillfree™ Attachment System
Specimen #5 Prior to Testing



Total Quality. Assured.

130 Derry Court
York, Pennsylvania 17406

Telephone: 717-764-7700
Facsimile: 717-764-4129
www.intertek.com/building

TEST REPORT FOR CARTER ARCHITECTURAL PANELS, INC.

Report No.: L6030.01-109-18

Date: 10/19/22

SECTION 12
DRAWINGS

The test specimen drawings have been reviewed by Intertek B&C and are representative of the test specimen(s) reported herein. Test specimen construction was verified by Intertek B&C per the drawings included in this report. Any deviations are documented herein or on the drawings.



CARTER/ETALBOND SYSTEM TESTING

FUSION AND EVO TEST



intertek
 Report #: L6030.01
 Date: 09/08/22
 Verified by: [Signature]

MATERIALS INFORMATION

SYSTEM TYPE: RS RIVETLESS
 JOINT SIZE: 0.5625
 MANUFACTURER: ETALBOND
 SYSTEM THICKNESS: 2.00 & 1.75
 ACM COLOR 1: SILVER METALLIC-[64 X 146]-4-FR 
 ACM COLOR 2: -- NONE -- 
 ACM COLOR 3: -- NONE -- 
 JOINT SEALANT: DOWSIL 795
 SEALANT COLOR 1:

ARCHITECT INFO:



GENERAL NOTES

- GENERAL CONTRACTOR IS RESPONSIBLE FOR COORDINATION OF ALL OTHER TRADES TO MAINTAIN ACCEPTABLE CONSTRUCTION TOLERANCES AND TO ENSURE ADJACENT CONSTRUCTION IS TRUE, PLUMB, AND LEVEL PRIOR TO PLACEMENT OF PANELS.
- PSC WILL NOT ASSUME RESPONSIBILITY FOR ERRORS OF OTHER TRADES FROM THE USE OF THESE DRAWINGS.
- THIS PANEL SYSTEM IS A RAIN SCREEN PANEL SYSTEM THAT REQUIRES WEATHERPROOF BARRIER BEHIND ALL PANELS. THE PANEL SYSTEM WILL ONLY PREVENT WATER PENETRATION WHEN USED IN CONJUNCTION WITH A PROPER WEATHER BARRIER THAT IS INSTALLED AS PER MANUFACTURER'S SPECIFICATIONS.
- ALL LIGHTS, SIGNAGE, DOWN SPOUTS, ETC., MUST BE ATTACHED TO THE BUILDING STRUCTURE, NOT TO THE ACM PANEL SYSTEM.
- LEAD TIMES ARE TYPICALLY 4-6 WEEKS FROM FINAL FIELD MEASUREMENTS. CHECK WITH PRODUCTION FOR JOB SPECIFIC LEAD TIME AT TIME OF PROJECT.

DRAWINGS ARE APPROVED FOR CONSTRUCTION

SYMBOLS & ABBREVIATIONS

A.F.F. = ABOVE FINISHED FLOOR
 A.B.M. = ABOVE BENCHMARK
 F.O. = FINISHED OPENING
 I.S. = INSIDE
 O.D. = OVERALL DIMENSION
 O.P.D. = OVERALL PANEL DIMENSION
 O.S. = OUTSIDE
 P.D. = PANEL DIMENSION
 P.S.C. = PENN STATE CONSTRUCTION
 REF. = REFERENCE
 R.O. = ROUGH OPENING
 SIM. = SIMILAR
 SUB. = SUBSTRATE
 U.N.O. = UNLESS NOTED OTHERWISE
 V.I.F. = VERIFY IN FIELD

 = ELEVATION REFERENCE  = DETAIL BUBBLE

 = COLUMN LINE

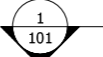
 = SECTION CUT

 = ELEVATION MARKER

GENERAL CONTRACTOR

STREET ADDRESS

FIRST LAST NAME PROJECT MANAGER
 (XXX) XXX-XXXX
 XXX@XXXX.com

FIRST LAST NAME FIELD SUPERINTENDENT
 (XXX) XXX-XXXX
 XXX@XXXX.com

DRAFTING INDEX

200: ELEVATION

ARCHITECTURAL PLANS REFERENCE

- PCNA 100% SUBMISSION
- NO ADDENDUMS

PROJECT NAME & LOCATION:
CARTER/ETALBOND SYSTEM TESTING

SHEET TITLE:
COVERSHEET

#	DATE	DESCRIPTION
6		
5		
4		
3		
2		
1		

CHECKED BY:
JPM

DWN BY:
EPS

DATE:
01/31/2022

JOB #:
22-001

SHEET:
CS

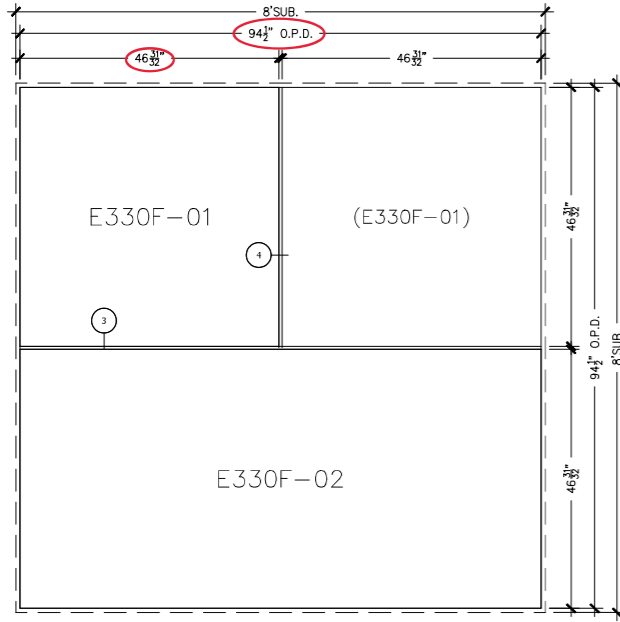

1 E330 FUSION TEST
 6 Total Elevations Scale: 3/4" = 1'-0"

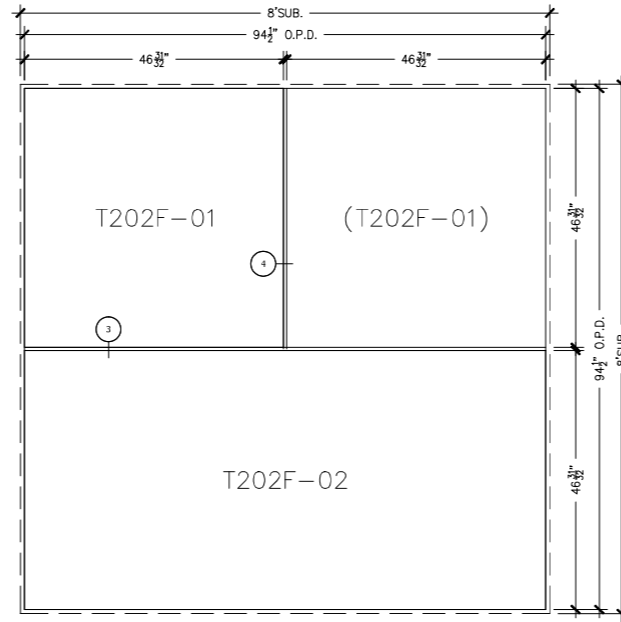

2 TAS202 FUSION TEST
 2 Total Elevations Scale: 3/4" = 1'-0"

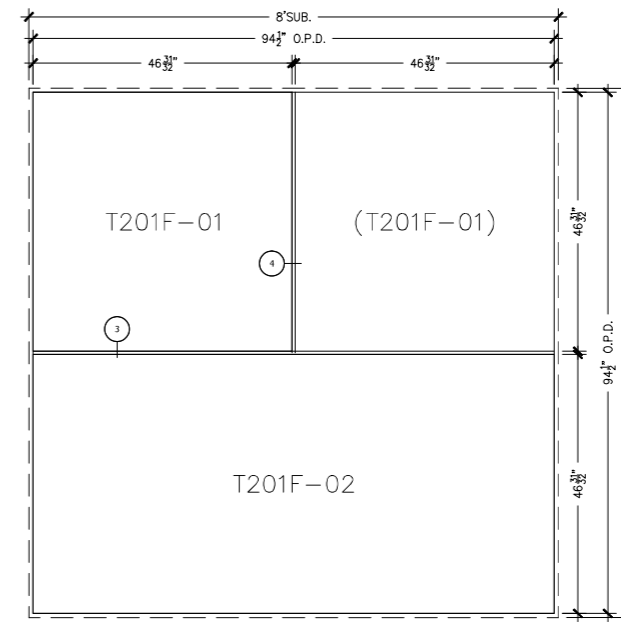

3 TAS201 / TAS203 FUSION TEST
 3 Total Elevations Scale: 3/4" = 1'-0"

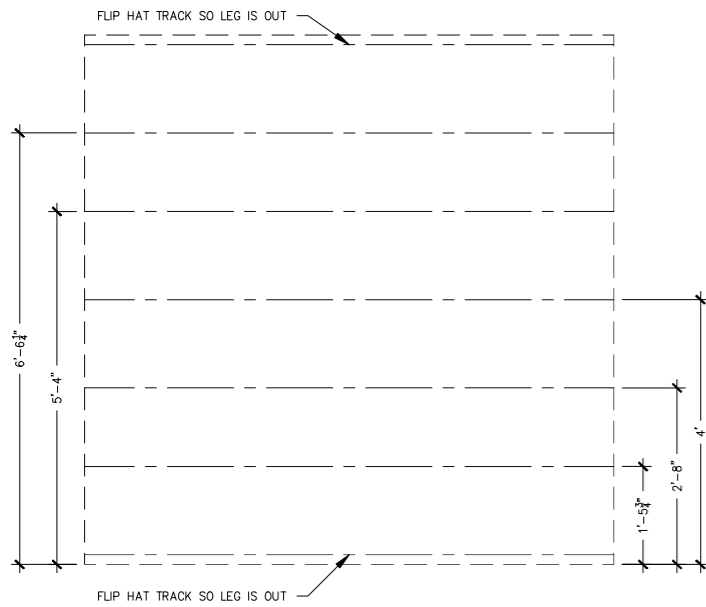

4 HAT TRACK LAYOUT
 11 Total Elevations Scale: 3/4" = 1'-0"

ARCHITECT INFO:

PROJECT NAME & LOCATION:
**CARTER/ETALBOND SYSTEM TESTING
 FUSION TESTING**

 SHEET TITLE:
FUSION ELEVATIONS

#	DATE	DESCRIPTION
6	---	---
5	---	---
4	---	---
3	---	---
2	---	---
1	---	---

CHECKED BY: JPM
DWN BY: EPS
DATE: 01/31/2022
JOB #: 22-001
SHEET: 200

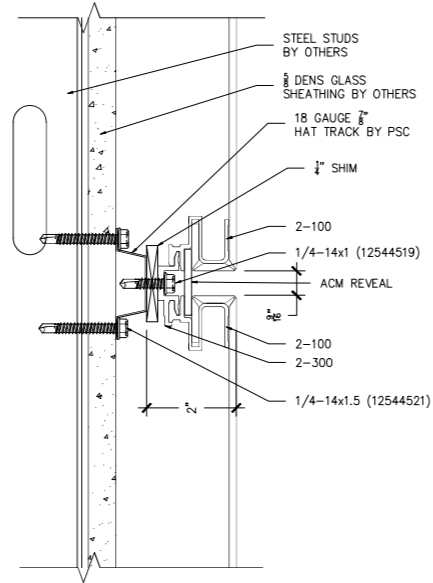

1 HORIZONTAL EVO JOINT DETAIL
 6" = 1'-0"

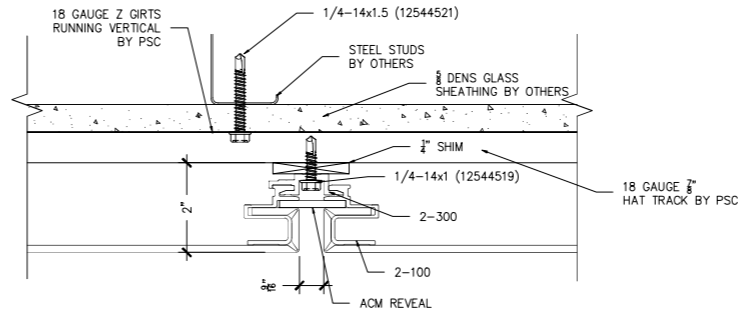

2 VERTICAL EVO JOINT DETAIL
 6" = 1'-0"

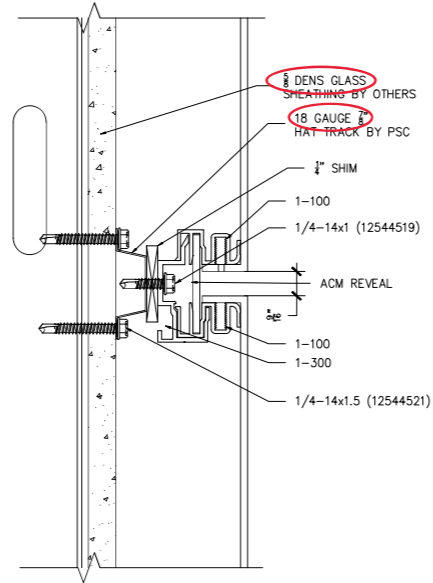

3 HORIZONTAL FUSION JOINT DETAIL
 6" = 1'-0"

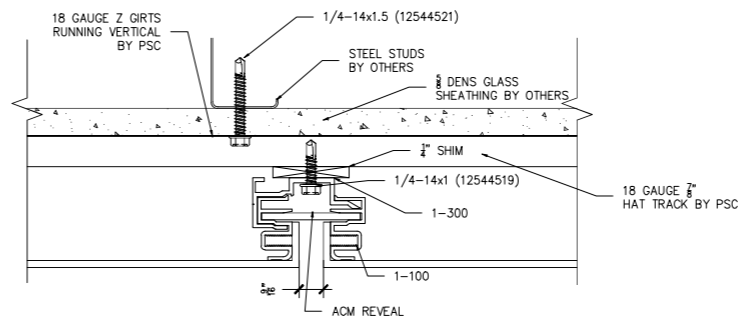

2 VERTICAL FUSION JOINT DETAIL
 6" = 1'-0"

ARCHITECT INFO:

PROJECT NAME & LOCATION:
CARTER/ETALBOND SYSTEM TESTING

SHEET TITLE:
DETAILS

#	DATE	DESCRIPTION
6	---	---
5	---	---
4	---	---
3	---	---
2	---	---
1	---	---

CHECKED BY:
JPM

DWN BY:
EPS

DATE:
01/31/2022

JOB #:
22-001

SHEET:
400

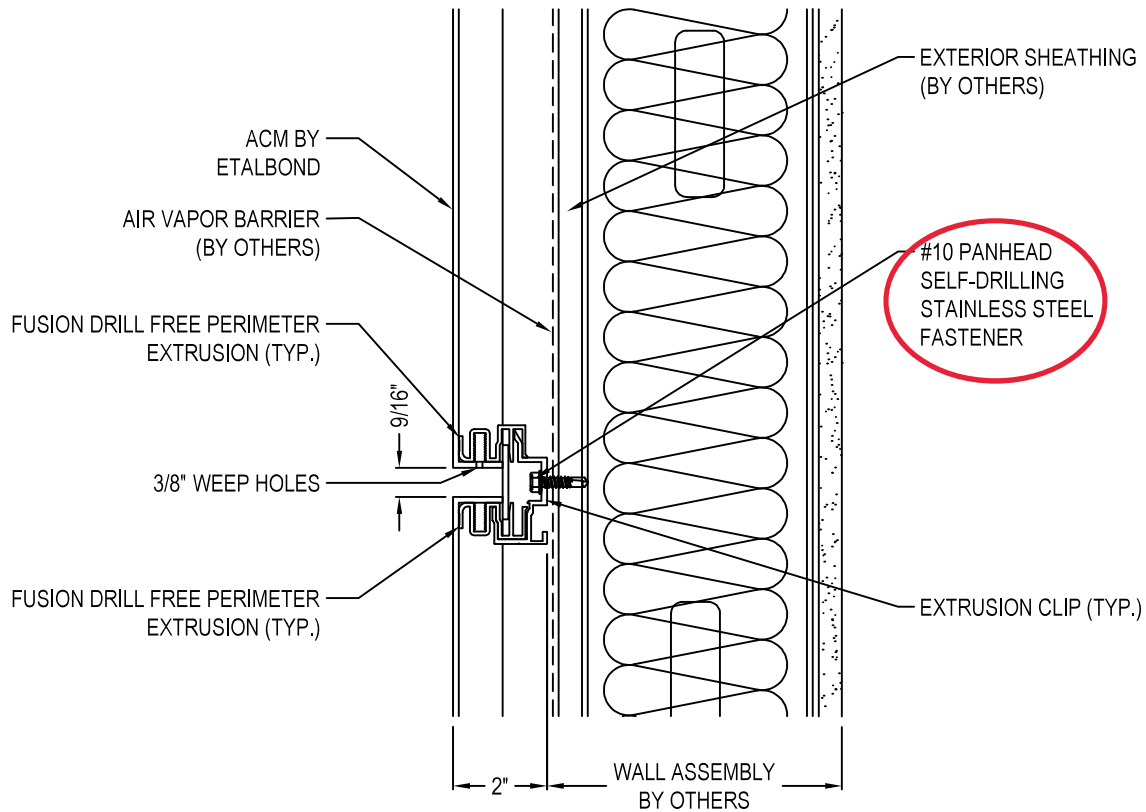

SECTION DETAIL

NOTES:

1. INSTALLATION TO BE COMPLETED IN ACCORDANCE WITH MANUFACTURER'S SPECIFICATIONS.
2. DO NOT SCALE DRAWING.
3. THIS DRAWING IS INTENDED FOR USE BY ARCHITECTS, ENGINEERS, CONTRACTORS, CONSULTANTS AND DESIGN PROFESSIONALS FOR PLANNING PURPOSES ONLY. THIS DRAWING MAY NOT BE USED FOR CONSTRUCTION.
4. ALL INFORMATION CONTAINED HEREIN WAS CURRENT AT THE TIME OF DEVELOPMENT BUT MUST BE REVIEWED AND APPROVED BY THE PRODUCT MANUFACTURER TO BE CONSIDERED ACCURATE.
5. CONTRACTOR'S NOTE: FOR PRODUCT AND COMPANY INFORMATION VISIT www.CADdetails.com/info AND ENTER REFERENCE NUMBER 5106-006

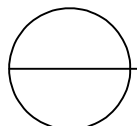

FUSION™ DRILLFREE™ PANEL SYSTEM

HORIZONTAL JOINT DETAIL (CF-F06)



Report #:	L6030.01
Date:	09/08/22
Verified by:	<i>J.R.Z.</i>

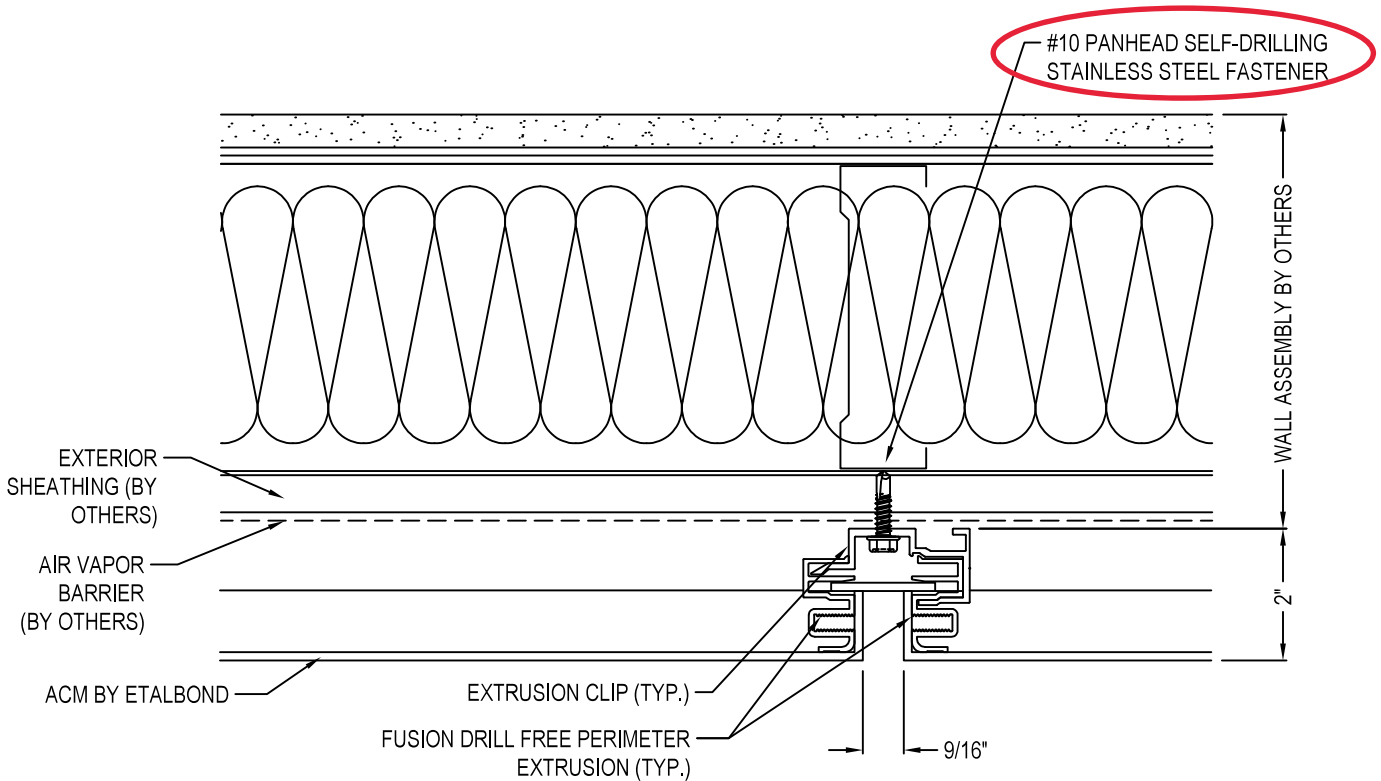

SECTION DETAIL

NOTES:

1. INSTALLATION TO BE COMPLETED IN ACCORDANCE WITH MANUFACTURER'S SPECIFICATIONS.
2. DO NOT SCALE DRAWING.
3. THIS DRAWING IS INTENDED FOR USE BY ARCHITECTS, ENGINEERS, CONTRACTORS, CONSULTANTS AND DESIGN PROFESSIONALS FOR PLANNING PURPOSES ONLY. THIS DRAWING MAY NOT BE USED FOR CONSTRUCTION.
4. ALL INFORMATION CONTAINED HEREIN WAS CURRENT AT THE TIME OF DEVELOPMENT BUT MUST BE REVIEWED AND APPROVED BY THE PRODUCT MANUFACTURER TO BE CONSIDERED ACCURATE.
5. CONTRACTOR'S NOTE: FOR PRODUCT AND COMPANY INFORMATION VISIT www.CADdetails.com/info AND ENTER REFERENCE NUMBER 5106-007

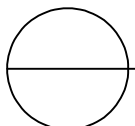

FUSION™ DRILLFREE™ PANEL SYSTEM

VERTICAL JOINT DETAIL (CF-F07)

CUSTOMER CARTER ARCHITECTURAL PANELS, INC	PART NO. -	DIE NO. AS-75434	DASH 1
DESCRIPTION: 6MM DRILL FREE PERIMETER RP	TARRIF# 7604.29.10.00	PROPOSAL# 35923-1	
HYDRO 5675 Kennedy Road Mississauga, Ontario L4Z 2H9		DATE	SYM
		REVISION	

PORTLAND DRAWING #
B-64191

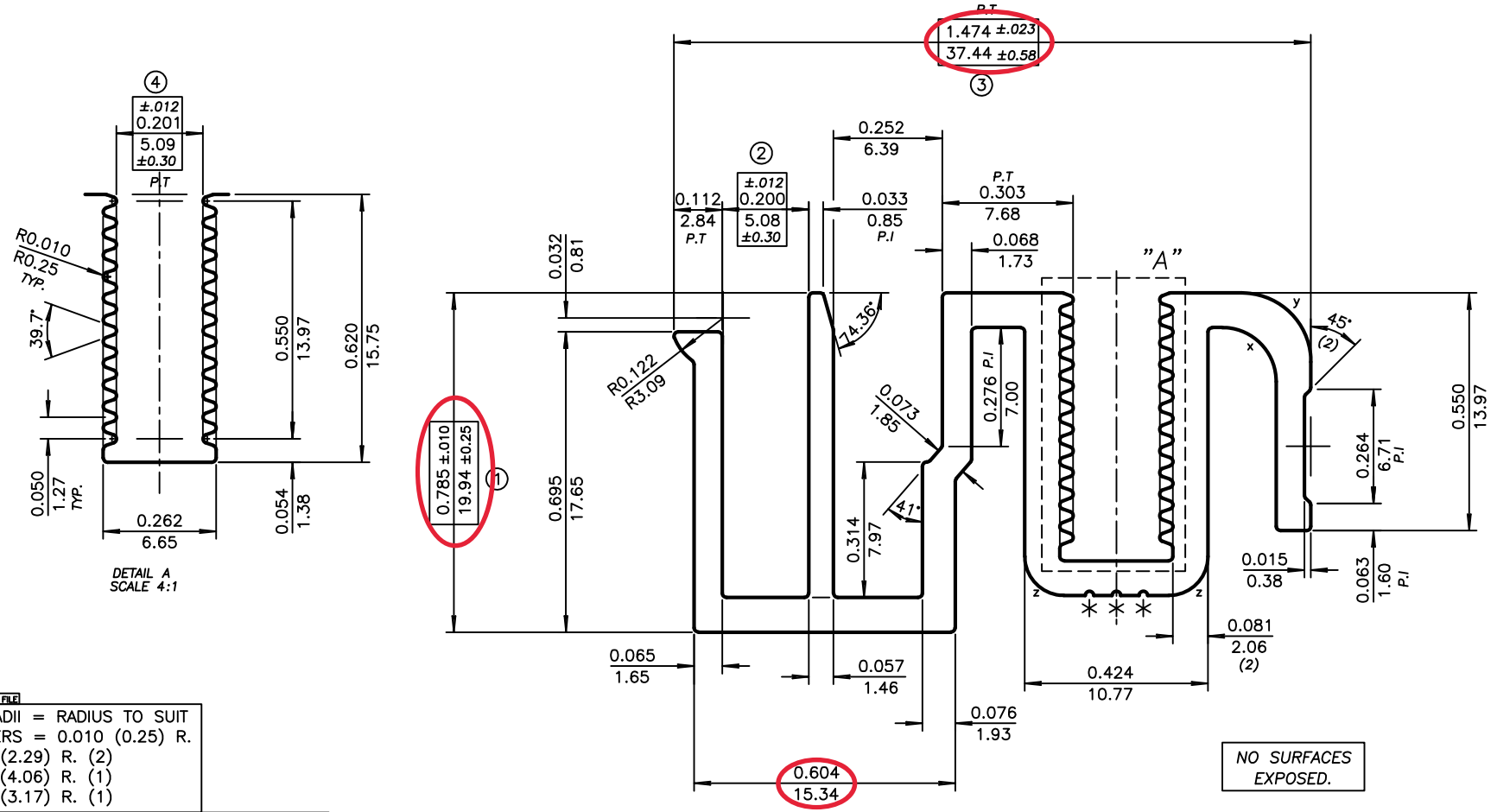

CUSTOMER'S SUPPLIED CAD FILE
UNMARKED RADII = RADIUS TO SUIT
BREAK CORNERS = 0.010 (0.25) R.
(z) = 0.090 (2.29) R. (2)
(y) = 0.160 (4.06) R. (1)
(x) = 0.125 (3.17) R. (1)

(*) = 0.010(0.25) R. X 0.010(0.25)D. HYDRO I.D. MARKS

	UNSPECIFIED WALL THICKNESS
	0.080(2.03) ±0.010(0.25)

SAMPLE APPROVAL
THIS SAMPLE IS APPROVED
AND SAPA
MAY PROCEED WITH PRODUCTION
SIGNED: _____
DATE: _____

NO SURFACES
EXPOSED.

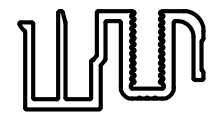

ACTUAL SIZE

EST. AREA	0.391 in ²	252 mm ²	OUT PER.	-	IN	-	MM
EST. WT.	0.469 LBS/FT.	0.698 KG/M	FACTOR	24			
EST. PER.	11.115 IN	282 MM	C.C.D.	1.573 IN	40 MM		
DWN BY	Vicki	ALLOY 6061-T6	SCALE	4:1	DATE	14,06,2018	

BREAK ALL CORNERS .016"R (0.41 mm)R UNLESS OTHERWISE NOTED. STANDARD ALUMINUM ASSOCIATION TOLERANCES TO APPLY UNLESS OTHERWISE SPECIFIED

CUSTOMER	CARTER FABRICATING INC.	PART NO.	009	DIE NO.	AS-72490	DASH	1
DESCRIPTION:	EVO INTEGRATED STIFFENER	TARRIF#	7604.29.10.00	PROPOSAL#	33592-1A	DATE	SYM
	SAPA 5675 Kennedy Road Mississauga, Ontario L4Z 2H9						REVISION

PACKAGING @ SAW

17pcs per row x 6 high

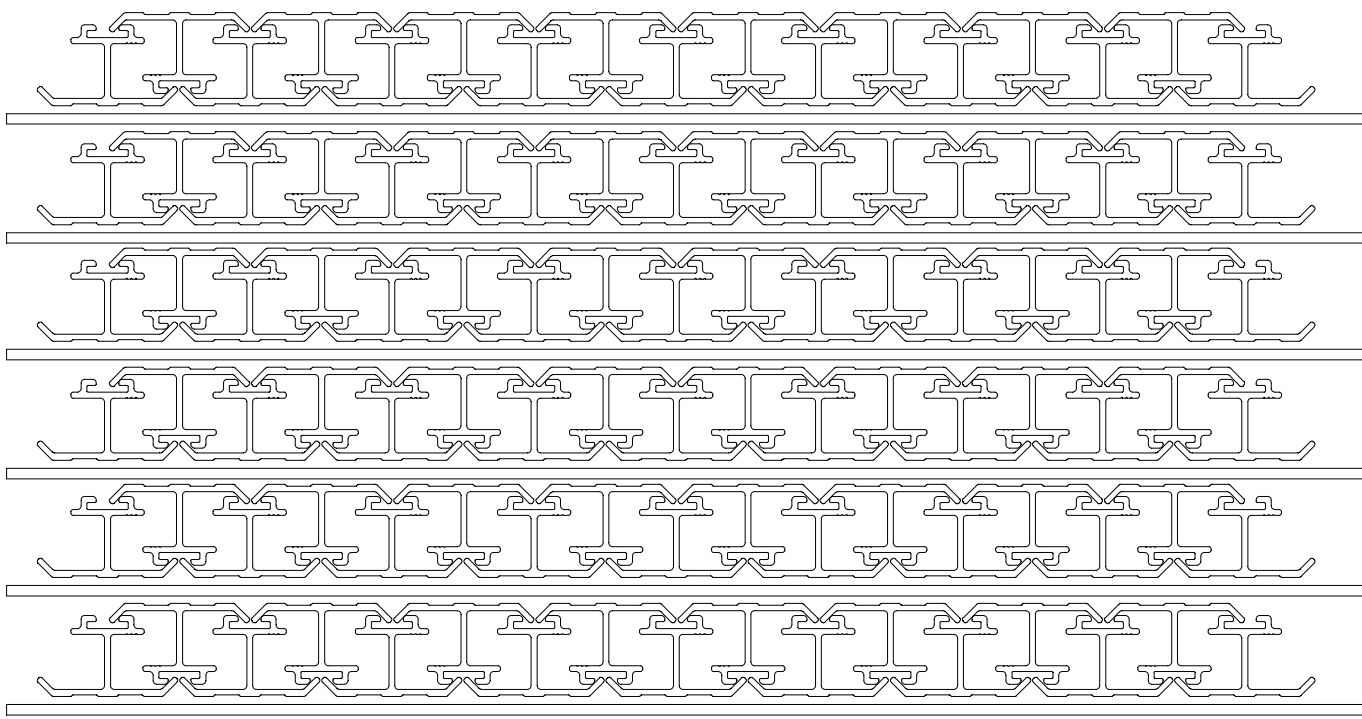
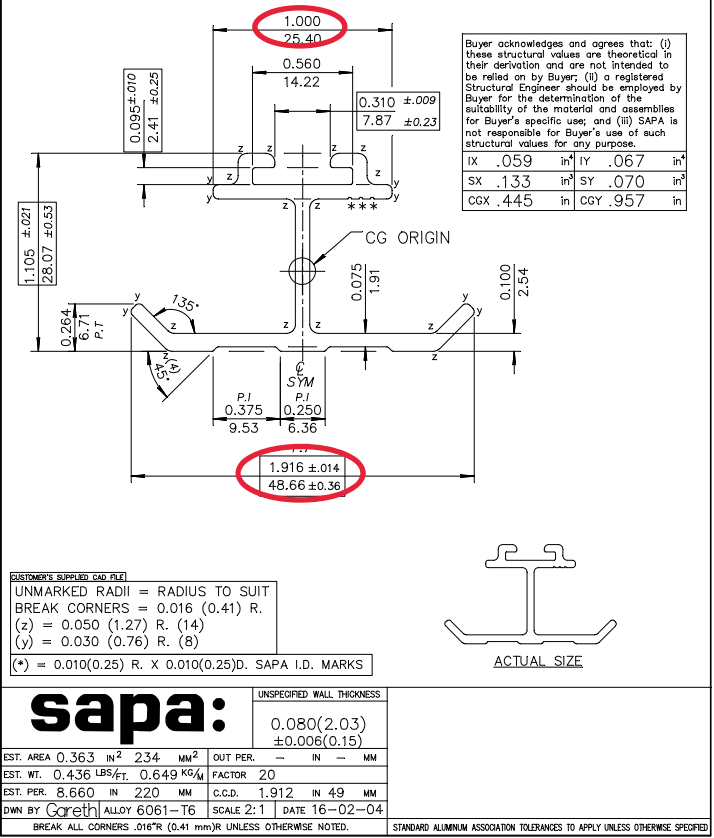

intertek
Total Quality. Assured.

Report #: L6030.01
 Date: 09/08/22
 Verified by: *J.R.Z.*



Total Quality. Assured.

130 Derry Court
York, Pennsylvania 17406

Telephone: 717-764-7700
Facsimile: 717-764-4129
www.intertek.com/building

TEST REPORT FOR CARTER ARCHITECTURAL PANELS, INC.

Report No.: L6030.01-109-18

Date: 10/19/22

SECTION 13

REVISION LOG

REVISION #	DATE	PAGES	REVISION
0	10/19/22	N/A	Original Report Issue